

**ELECTROLUX OUTDOOR PRODUCTS**

<b>PNC</b>	<b>Type/Prefix/nd</b>	<b>Model</b>	<b>Brand</b>
953900445	04	CABRIO 291	McCULLOCH
953900244	04	CABRIO 261	McCULLOCH
953900447	04	B 291	PARTNER
953900250	04	B 261	PARTNER
953900642	04	B 291 TNG	PARTNER

Number of Pages 1 of 5

<b>Factory:</b> IIQ - Valmadrera	<b>Product Group:</b> OP 93
<b>Publication Number:</b> EIPL2005_VP0504005	<b>Petrol Portable</b>
<b>Publication Date:</b> 07/04/05	<b>Sub Group</b> 9433

Service

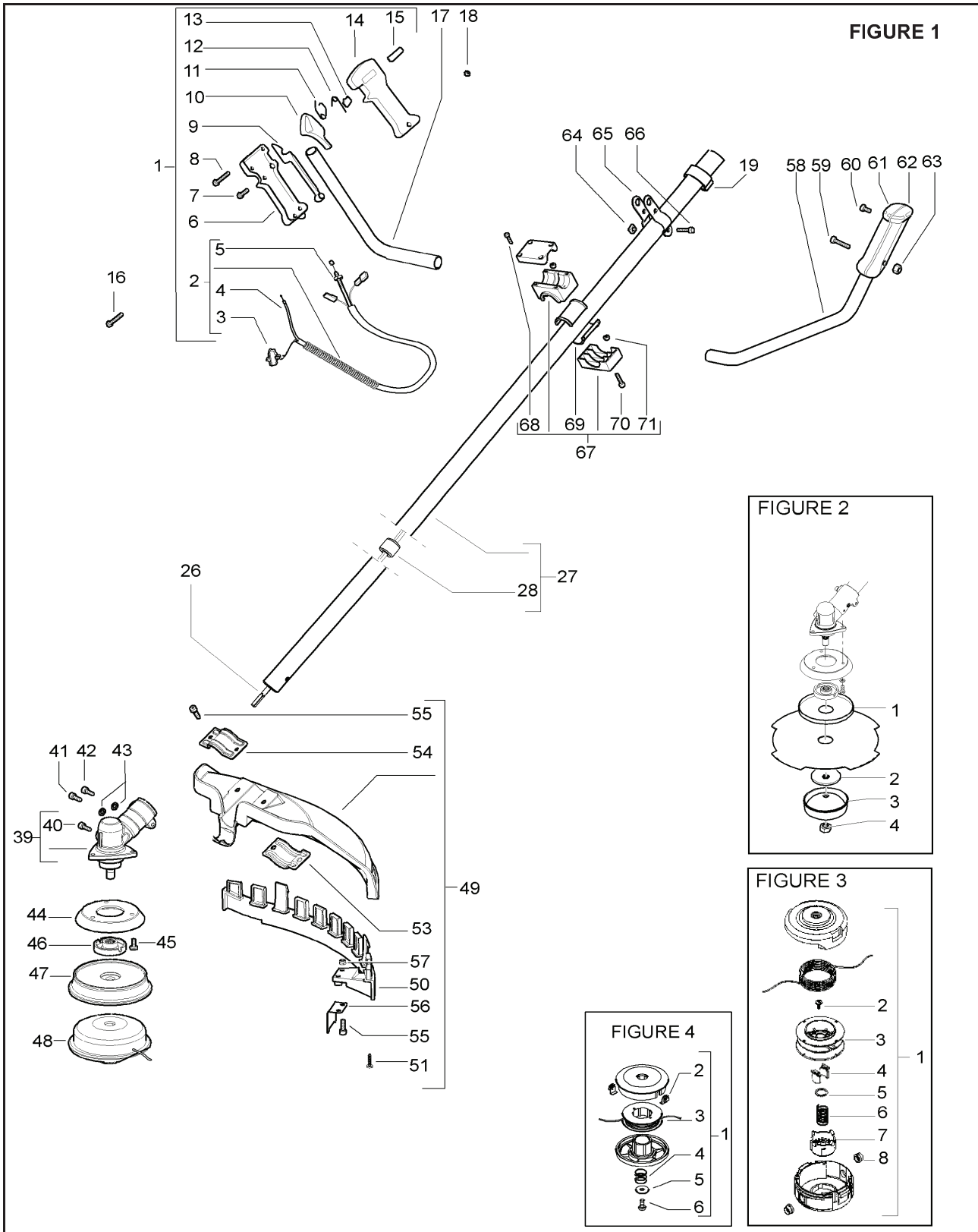

Item	P/N McC	P/N ELX	Qty	DESCRIPTION
<b>FIGURE 1</b>				
1	227089	538227089	1	trigger box assy
C 2	• 227082	538227082	1	cable assy
C 3	•• 236394	538236394	1	switch
C 4	•• 227054	538227054	1	throttle cable
5	• 235912	538235912	1	nut M6
6	• 241293	538241293	1	half handle (right)
7	• 240618	538240618	2	screw 3x16
8	• 240833	538240833	3	screw 3x20
9	• 229820	538229820	1	safety lever
10	• 241295	538241295	1	throttle trigger
11	• 240091	538240091	1	throttle trigger spring
12	• 229973	538229973	1	throttle advance spring
13	• 229823	538229823	1	throttle advance
14	• 241294	538241294	1	half handle (left)
15	• 229824	538229824	1	throttle advance slide
16	235804	538235804	1	screw M5x30
17	229831	538229831	1	right handle bar
18	235216	538235216	1	nut M5
19	229850	538229850	2	cable retain
26	240486	538240486	1	drive shaft
27	242442	538242442	1	shaft assy
28	• 228192	538228192	5	bushing
39	242728	538242728	1	gear box
40	• 240151	538240151	1	screw M8x10
41	235802	538235802	1	screw 5x14
42	235803	538235803	1	screw 5x25
43	236529	538236529	2	split washer
44	242729	538242729	1	flange adapter
45	240688	538240688	3	screw M5 and washer
A 46	242815	538242815	1	flange
B 47	242823	538242823	1	spacer (TNG string head)
B 47	241155	538241155	1	spacer (standard string head)
A 48		<b>FIGURE 3</b>	1	string head (TNG)
A		<b>FIGURE 4</b>	1	string head (standard)
B 49	• 249155	538249155	1	guard ass'y
B 50	• 242644	538242644	1	guard extension
51	• 240862	538240862	1	screw M5x14
53	• 242752	538242752	1	lower clamp
54	• 242629	538242629	1	upper clamp
55	• 227563	538227563	4	screw M5x16
56	• 241973	538241973	1	line cutter
57	• 229208	538229208	2	nut
58	229832	538229832	1	left handle bar
59	235212	538235212	1	screw M5x35
60	240833	538240833	1	screw M3x20
61	229985	538229984	1	left handle (right half)
62	229984	538229985	1	left handle (left half)
63	235216	538235216	1	nut M5

Item	P/N McC	P/N ELX	Qty	DESCRIPTION
64	236642	538236642	2	nut M6
65	228152	538228152	2	harness clamp (1 half)
66	235911	538235911	2	screw M6x12
67	241685	538241685	1	handle clamp assy
68	• 236558	538236558	4	screw M6x40
69	• 241684	538241684	2	half bearing
70	• 235911	538235911	2	screw M6x30
71	• 235912	538235912	6	nut M6

<b>FIGURE 2</b>				
B 1	241155	538241155	1	flange
A 2	241006	538241006	1	plate blade
A 3	236596	538236596	1	cup
A 4	240481	538240481	1	nut

<b>FIGURE 3 TNG STRING HEAD</b>				
A 1	538249346	538249346	1	string head
2	• 249374	538249374	1	set screw
C 3	• 249375	538249375	1	reel
C 4	• 249376	538249376	2	ratchet
C 5	• 249377	538249377	1	washer
C 6	• 249378	538249378	1	return spring
C 7	• 249379	538249379	1	button
C 8	• 249380	538249380	2	eyelet

<b>FIGURE 4 STANDARD STRING HEAD</b>				
A 1	538249174	538249174	1	string head
B 2	• 241154	538241154	2	eyelet
B 3	• 247395B	538047395	1	2 line spools
4	• 240852	538240852	1	spring
5	• 5210	538005210	1	locking nut
6	• 229712	538229712	1	screw 5x16

A=ALTA ROTAZIONE	A=HIGH MOVING	A=HAUTE DEMANDE	A=GROBE NACHFRAGE
B=MEDIA ROTAZIONE	B=MEDIUM MOVING	B=MOYENNE DEMANDE	B=MITTELMAESSIGE
C=ALTA ROTAZIONE	C=SLOW MOVING	C=BASSE DEMANDE	C=WENIGE NACHFRAGE
NUOVI CODICI	NEW P. NUMBERS	NOUVELLES REFERENCES	NEU CODEX

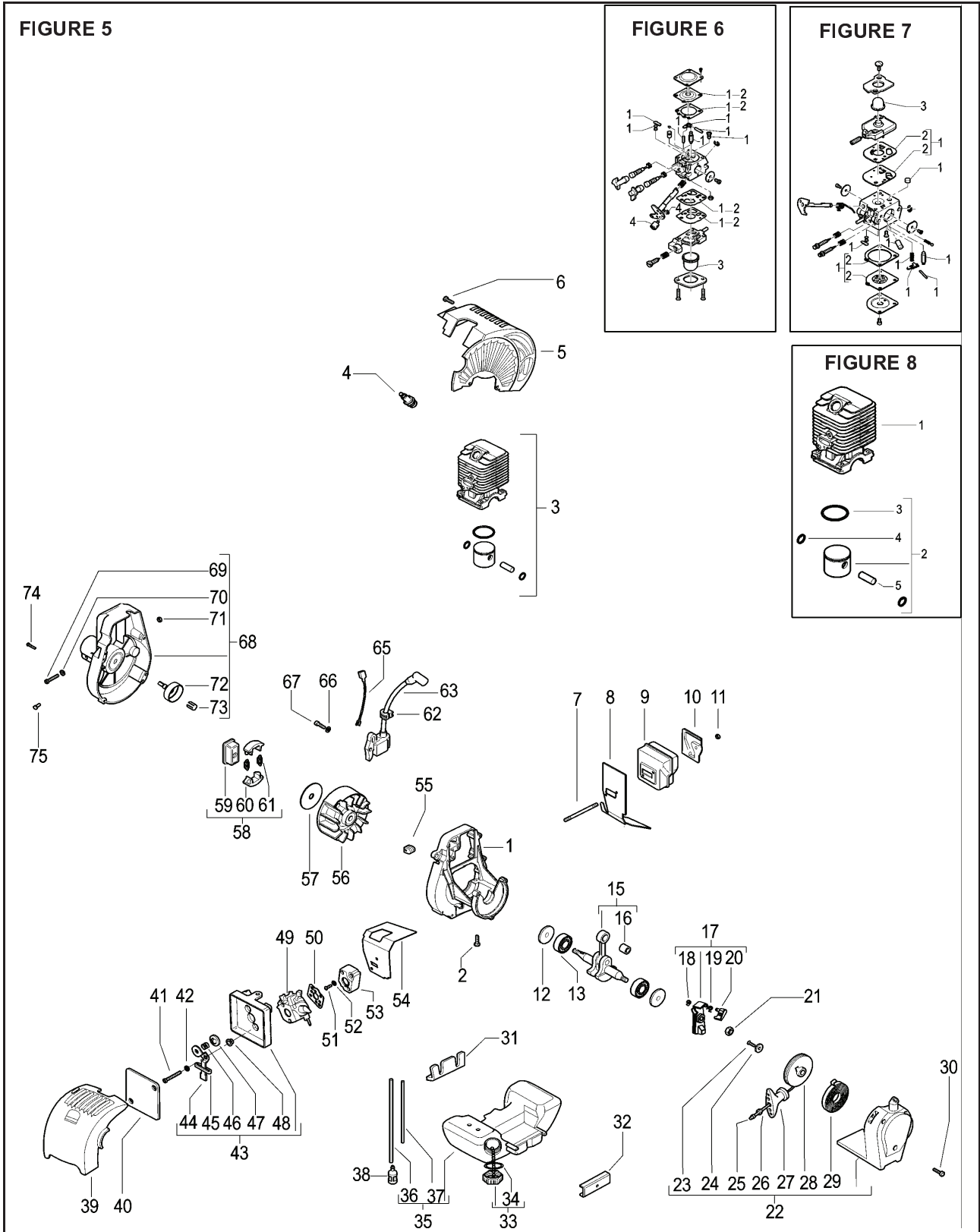

Item	P/N McC	P/N ELX	Qty	DESCRIPTION
<b>FIGURE 5</b>				
1	242802	538242802	1	crankcase
2	227565	538227565	4	screw M5x25
3	<b>FIGURE 8</b>			
A 4	92879	538092879	1	spark plug RDJ8J
5	242704	538242704	1	engine cover
6	241963	538241963	2	screw M4x22
7	242037	538242037	2	stud bolt
B 8	243273	538243273	1	exhaust gasket
C 9	242131	538242131	1	muffler
10	323760	538323760	1	muffler shield
11	235642	538235642	2	nut M5
C 12	242994	538242994	2	seal
C 13	241594	538241594	2	ball bearing
15	243486	538243486	1	crankshaft assy
C 16	• 235742	538235742	1	needle bearing
17	241784	538241784	1	starter pawl assy
18	• 111088	538111088	1	snap ring
19	• 241782	538241782	1	spring
20	• 241781	538241781	1	pawl
21	235248	538235248	1	nut
C 22	242041	538242041	1	starter assy
23	• 240862	538240862	1	screw M4x18
24	• 241703	538241703	1	washer
A 25	• 241746	538241746	1	rope
26	• 235612	538235612	1	washer
27	• 241778	538241778	1	handle
B 28	• 241620	538241620	1	pulley
B 29	• 241619	538241619	1	spring
30	241963	538241963	3	screw M4x20
31	242038	538242038	1	tank grommet (crankcase side)
32	242039	538242039	1	tank grommet (starter side)
B 33	242484	538242484	1	fuel tank cap assy
A 34	• 236564	538236564	1	gasket
C 35	242040	538242040	1	fuel tank assy
B 36	• 229717	538229717	1	hose
B 37	• 229743	538229743	1	primer bulb hose
A 38	93720	538093720	1	fuel pickup
39	242703	538242703	1	air filter cover
B 40	242035	538242035	1	air filter
41	235808	538235808	2	screw 5x50
42	235248	538235248	1	washer
43	248485	538248485	1	air box assy
44	• 241769	538241769	1	choke lever
45	• 241622	538241622	1	choke lever grommet
46	• 235822	538235822	1	spring
47	• 241602	538241602	1	choke shutter
48	• 227022	538227022	2	bushing
C 49	<b>FIGURE 6 / FIGURE 7</b>			
A 50	241600	538241600	1	carb. Gasket
51	235806	538235806	2	screw M5x20
52	235248	538235248	2	washer

Item	P/N McC	P/N ELX	Qty	DESCRIPTION
B 53	241750	538241750	1	carb. Spacer
B 54	242860	538242860	1	intake gasket
55	241607	538241607	1	grommet
56	243311	538243311	1	flywheel
57	241604	538241604	1	dust shield
B 58	241793	538241793	1	clutch assy
59	• 241789	538241789	1	clutch hub
60	• 241743	538241743	2	clutch shoe
A 61	• 241794	538241794	2	clutch spring
62	236322	538236322	1	grommet
C 63	243429	538243429	1	ignition coil
65	241606	538241606	1	ground wire
66	235248	538235248	2	washer
67	235806	538235806	2	screw M5x20
C 68	241725	538241725	1	joint assy
69	• 235803	538235803	1	screw M5x25
70	• 235248	538235248	1	washer
71	• 229524	538229524	1	nut M5
72	• 241785	538241785	1	clutch drum
73	• 228260	538228260	1	pin
74	227568	538227568	4	screw M4x20
75	236981	538236981	1	screw 3,5x9,5

<b>FIGURE 6 WALBRO WT 686</b>				
C -	242932	538242932		carb.
B 1	• 324013	538324013		K20 rep. Kit
A 2	•• 324009	538324009		D20 gasket kit
C 3	• 225834	538225834		primer bulb
4	• 224466	538224466		swivel kit

<b>FIGURE 7 ZAMA C1Q M38</b>				
C -	-	-		carb.
B 1	• 300465	538300465		RB-28 rep.kit
A 2	•• 300473	538300473		diaph/gasket kit
C 3	• 246946	538246946		primer bulb

<b>FIGURE 8 cylinder,piston 25cc</b>				
C 1	242803	538242803	1	cylinder
C 2	248177	538248177	1	piston kit
B 3	• 240002	538240002	1	piston ring
4	• 235008	538235008	2	snap ring
5	• 241735	538241735	1	piston pin

<b>FIGURE 8 cylinder, piston 29cc</b>				
C 1	243076	538243076	1	cylinder
C 2	249179	538249179	1	piston kit
B 3	• 242602	538242602	1	piston ring
4	• 235008	538235008	2	snap ring
5	• 241735	538241735	1	piston pin

A=ALTA ROTAZIONE	A=HIGH MOVING	A=HAUTE DEMANDE	A=GROBE NACHFRAGE
B=MEDIA ROTAZIONE	B=MEDIUM MOVING	B=MOYENNE DEMANDE	B=MITTELMAESSIGE
C=ALTA ROTAZIONE	C=SLOW MOVING	C=BASSE DEMANDE	C=WENIGE NACHFRAGE
NUOVI CODICI	NEW P. NUMBERS	NOUVELLES REFERENCES	NEU CODEX

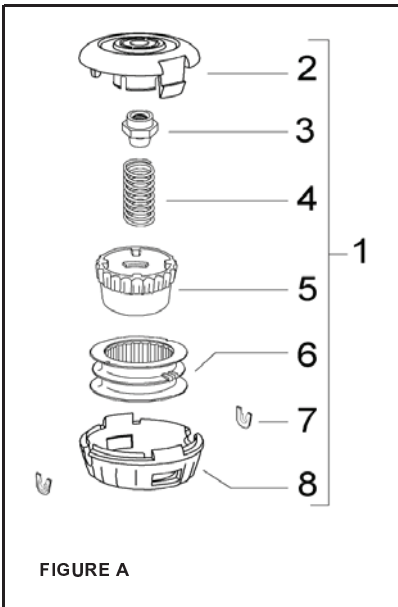

**FIGURE A**

A	1	531025001	531025001	1	P 25 trimmer head
	2	• 537419302	537419302	1	body
	3	• 537338901	537338901	1	adapter T25
C	4	• 537338801	537338801	1	spring T25
C	5	• 537419601	537419601	1	knob
C	6	• 537419501	537419501	1	spool whithout line
C	7	• 537419701	537419701	2	bushing
	8	• 537419401	537419401	1	cover

A=ALTA ROTAZIONE  
 B=MEDIA ROTAZIONE  
 C=ALTA ROTAZIONE

A=HIGH MOVING  
 B=MEDIUM MOVING  
 C=SLOW MOVING

A=HAUTE DEMANDE  
 B=MOYENNE DEMANDE  
 C=BASSE DEMANDE

A=GROBE NACHFRAGE  
 B=MITTELMAESSIGE  
 C=WENIGE NACHFRAGE

NUOVI CODICI

NEW P. NUMBERS

NOUVELLES REFERENCES

NEU CODEX